

MRS600.26

Diodes module

Features:

- Isolated mounting base 3000V~
- Pressure contact technology with increased power cycling capability
- Space and weight savings



Typical applications:

- AC/DC motor drives
- Various rectifiers
- DC supply for PWM inverter

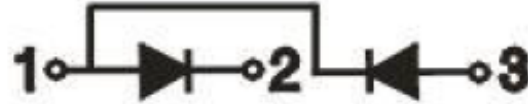

Symbol	Characteristics	Test Conditions	Value			Unit
			Min	Typ	Max	
$V_{RSM/DSM}$	Non-repetitive reverse/forward blocking voltage	$T_j = 150^\circ\text{C}$			2700	V
$V_{RRM/DRM}$	Repetitive reverse/forward blocking voltage	$T_j = 150^\circ\text{C}$			2600	V
$I_{F(AV)}$	Forward average current	180° half sine wave 50Hz $T_c = 106^\circ\text{C}$			600	A
$I_{F(RMS)}$	Forward square root current	180° half sine wave 50Hz $T_c = 106^\circ\text{C}$			942	A
I_{RRM} I_{DRM}	Repetitive peak current	at V_{DRM}/V_{RRM} $T_j = 150^\circ\text{C}$			40	mA
I_{FSM}	Forward surge current	10ms half sine wave without reverse voltage $T_j = 150^\circ\text{C}$			29	kA
$I^2 t$	$I^2 t$ for fusing coordination				4205	kA^2s
V_{FO}	Threshold voltage	$T_j = 150^\circ\text{C}$			0.914	V
r_F	Forward slope resistance	$T_j = 150^\circ\text{C}$			0.145	$\text{m}\Omega$
V_{FM}	Peak forward voltage	$T = 25^\circ\text{C}$; $I_F = 1500\text{A}$			1.18	V
$R_{th(j-c)}$	Thermal resistance junction to case	Single side cooled per chip			0.065	$^\circ\text{C}/\text{W}$
$R_{th(c-s)}$	Thermal resistance case to sink	Single side cooled per chip			0.020	$^\circ\text{C}/\text{W}$
V_{ISO}	Isolation voltage	50Hz, RMS, $t = 1\text{min}$, $I_{ISO} : 1\text{mA (MAX)}$	3000			V
F_M	Mounting torque - copper plate (M6)			6.0		N·m
	Mounting torque - terminal (M10)			12.0		N·m
T_{stg}	Storage Temperature		-40		150	$^\circ\text{C}$
T_j	Operating Temperature		-40		150	$^\circ\text{C}$
W_t	Weight			1480		g
Outline		M90				

DISSIPATION CHARACTERISTICS
SINE WAVE

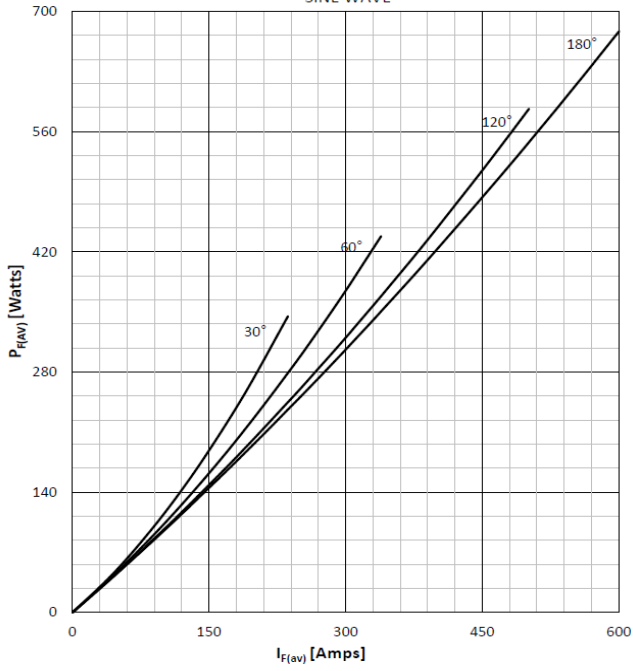

FORWARD CURRENT DERATING CURVE
SINE WAVE

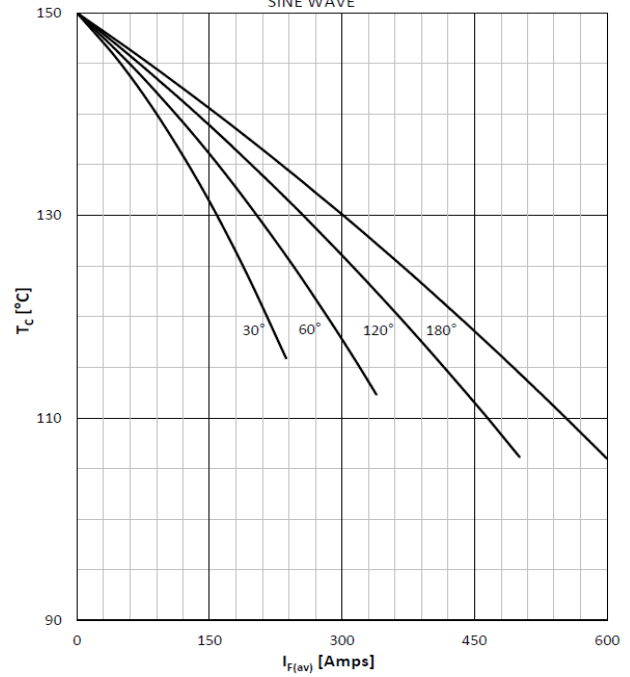

DISSIPATION CHARACTERISTICS
SQUARE WAVE

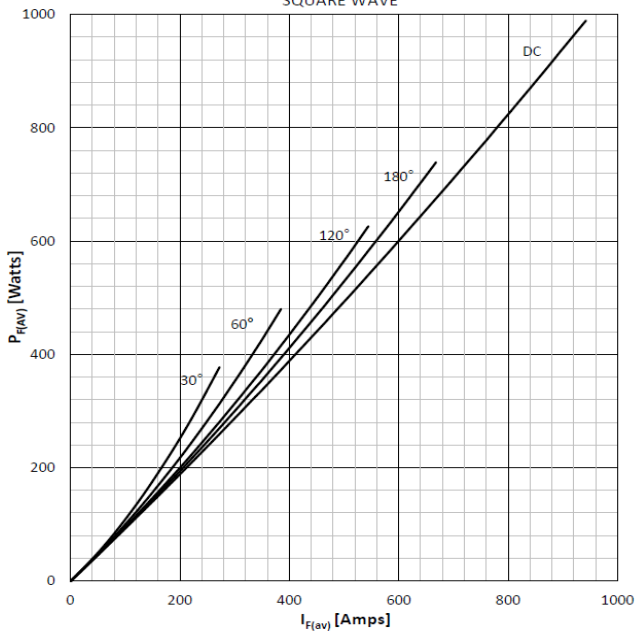

FORWARD CURRENT DERATING CURVE
SQUARE WAVE

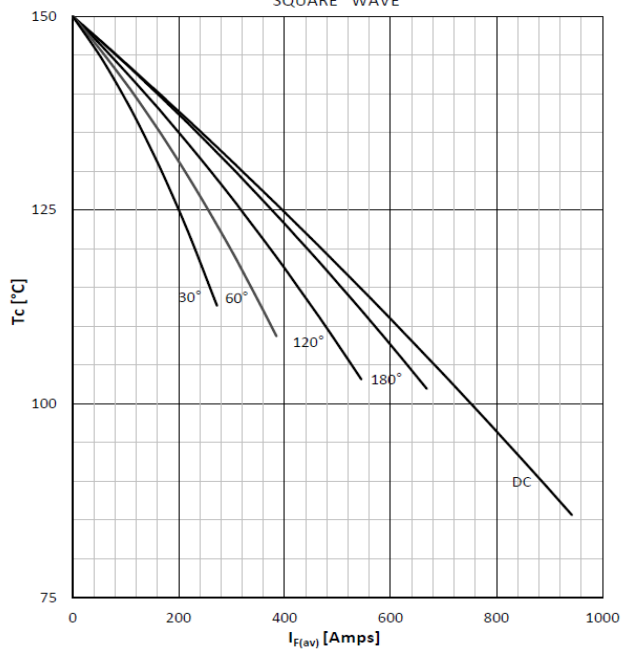

FORWARD CHARACTERISTIC

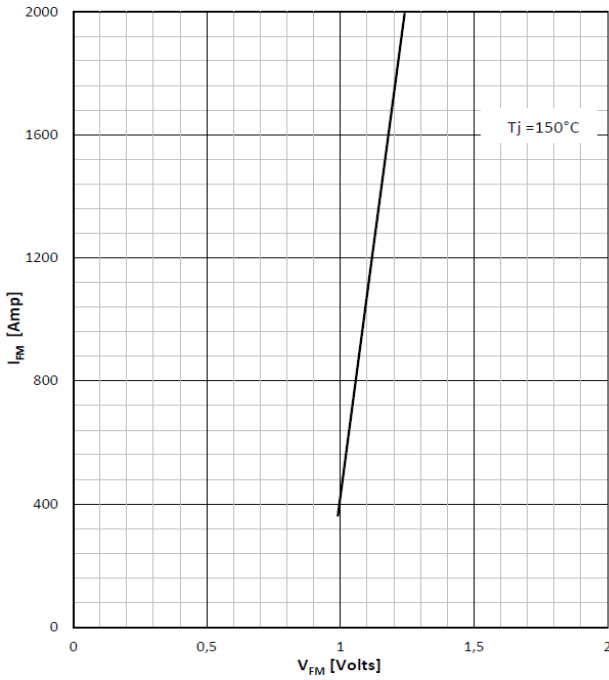

SURGE CHARACTERISTICS

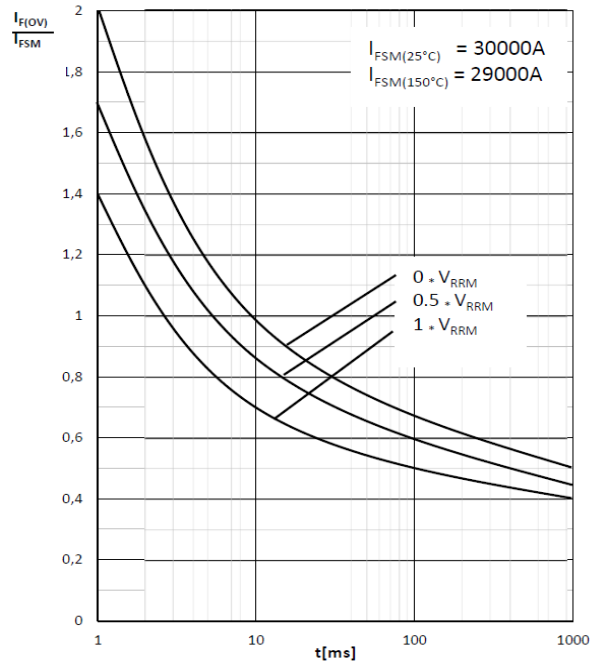

TRANSIENT THERMAL IMPEDANCE

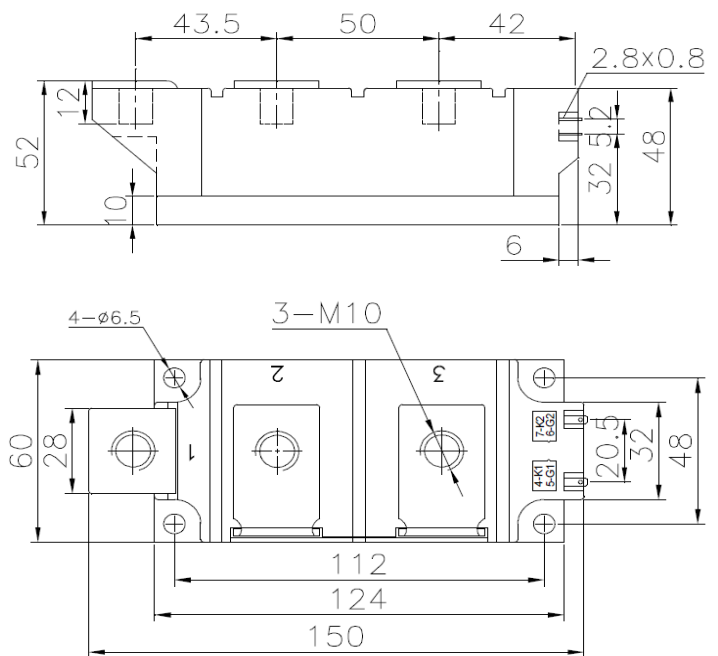
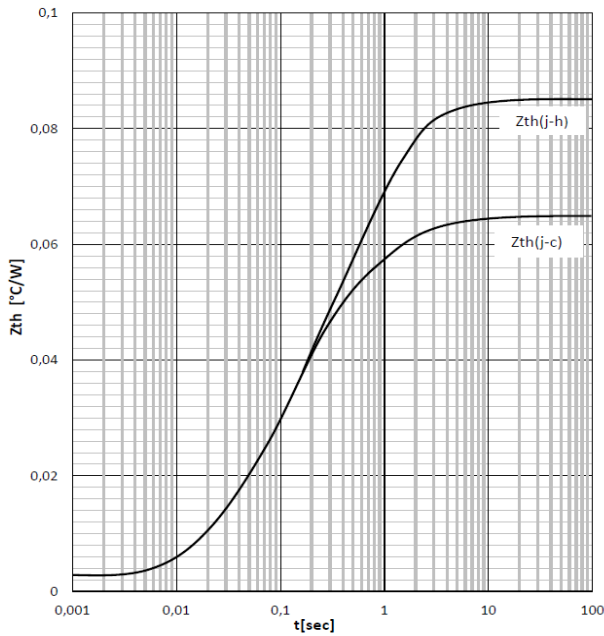

(dimensions in mm)

S.CO.M.E.S. Srl

Via Enrico Mattei, 6/8 - 26283 - Castiglione d'Adda (LO) - Italy

Phone: +39 0377 901243 Fax: +39 0377 900206